

Small dimensions



high productivity



easy transport



90° agility

Authorized distributor and manufacturer:

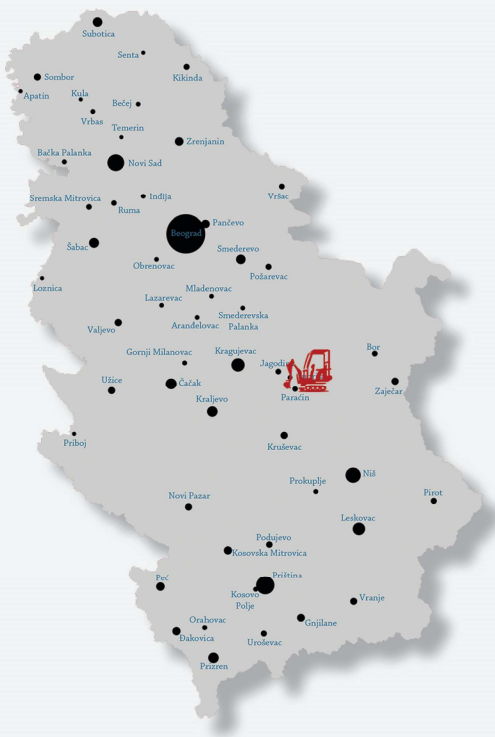

AXPAN
PRO

MINI MACHINES

ENGLISH LANGUAGE



AXPOT36 plus



AXPAN
PRO

AXPOT36 plus
Technical data

Engine and hydraulic system specification

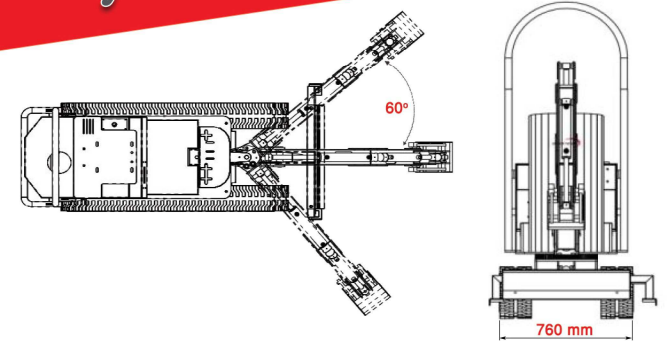
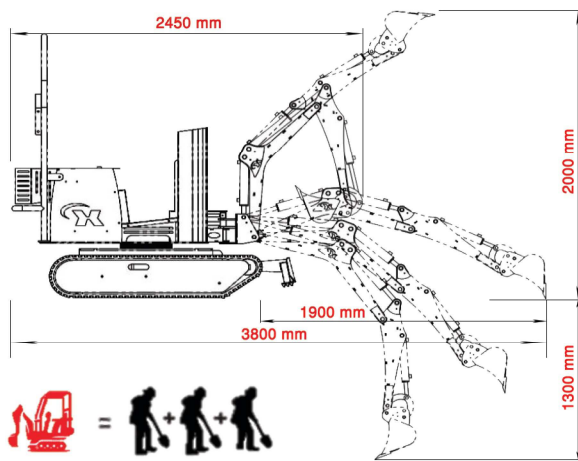

RIPPER TOOTH

For compacted soil, shallow narrow trenches, pulling out roots, etc...



20cm BUCKET (8")

Trenching bucket with teeth



30cm BUCKET (12")

General purpose bucket with teeth



60cm BUCKET (24")

Grading or ditching bucket without teeth. Can be mounted facing forward for scooping up



Operating weight	680 kg	1499 lbs
Overall length	2,513 mm	99 inch
Total height	1,950 mm	77 inch
Height with ROPS folded	1,420 mm	56 inch
Width	760 mm	30 inch
Track width	180 mm	7 inch
Footprint	1,200 mm	47 inch
Ground clearance	180 mm	7 inch
Maximum digging depth	1,300 mm	51 inch
Bucket digging force	800 daN	1.800 lbf
Maximum lifting capacity	100 kg	220 lbs
Maximum travel speed	2 km/h	1.25 mph
Boom slew angle	120° (60° right + 60° left)	

Engine specification

Gross power @ 3,600 rpm	14 hp
Displacement	429 cm ³
Engine weight	31 kg
Oil capacity	1.1 L
Fuel tank	6,6 L

Briggs & Stratton xr2100

Gross power @ 3,600 rpm	14 hp	10,4 kW
Displacement	429 cm ³	26,18 in. ³
Engine weight	31 kg	68 lbs
Oil capacity	1.1 L	1,16 USqt
Fuel tank	6,6 L	7 USqt
Hydraulic system	Italian twin gear pump gr1 upgraded for 14hp option, cooling radiator	
Displacement	4,8cc + 4,8cc	0,29in. ³ per pump
Flow rate 1700 rpm	8,2 + 8,2 L/min	2.16 USgal/min/pump
Maximum operating pressure	160 bars	2,320 psi
Reservoir capacity	25 L	6,5 USgal

